

Presented at the 31st PTTI meeting in Dana Point, Ca, USA in December 1999

ON AN IMPROVED METHOD OF RESOLVING THE FREQUENCY DIFFERENCE BETWEEN TWO VERY ACCURATE AND STABLE FREQUENCY SIGNALS

RICHARD PERCIVAL and CLIVE GREEN,

QUARTZLOCK (UK) LTD,

Abstract

With the advance in accuracy and stability of modern atomic clocks, the need for a very precise method of detecting instabilities in their signals has arisen. For example, with two hydrogen masers with a 1 in 10^{15} frequency difference, the drift rate of phase due to the frequency difference will be 1fs per second or 3.6ps per hour. No ordinary universal counter would be capable of resolving the difference between the two signals.

In response to this need, a state of the art, computer based very high resolution frequency and time interval measurement system has been developed. The measurement system integrates the most advanced phase Comparators with modern PC time interval counting techniques. Software consists of Stable32TM routines capable of measuring both first and second difference variances. Internally the system also has a high stability rubidium oscillator and a high isolation 4 output distribution amplifier.

With a hydrogen maser reference in a temperature controlled room, the A7 specifications state short-term stability (Allan Variance) of $1.5E-13$ /gate time, resulting in $1.5E-13$, $1.5E-14$ and $1.5E-15$ for 1s, 10s and 100s gate times (τ). Initial results suggest even better performance than this with Allen variances of $5E-14$, $8E-15$, $9E-16$ and $3.5E-16$ for 1s, 10s, 100s and 1000s gate times (τ). The Noise Floor is reached after about 1000s

Constant ambient temperature ensures typical drift of 2ps/hr. A 1 °C temperature change adds less than 10ps. A single shot rms. resolution of 0.3ps was also measured, enabling the A7 to easily resolve the 3.6ps/hr drift rate between two hydrogen masers.

The primary benefits of the A7 are improved accuracy and reduced measurement time. Fast measurements with high accuracy permit greater knowledge of the stability of the signal.

The applications for a measurement instrument capable of such resolution are anticipated to be numerous, ranging from national standards and calibration laboratories, through Cesium, Rubidium and Quartz production to time transfer measurements.

Further work on reducing the size and improving the resolution is being carried out.

1. Introduction

In 1952, the first digital electronic counter was introduced. As a result it became possible for frequency measurement of up to and including 10 MHz to be made, or a 100ns resolution of time between two events. [1]

It is almost 50 years since this instrument was first brought out, and electronic counters have advanced rapidly since then. Several different techniques have been developed to increase the accuracy and resolution of electronics counters. [2]

Presented at the 31st PTTI meeting in Dana Point, Ca, USA in December 1999

With the huge advance in accuracy and stability of modern atomic clocks, the need for a very precise method of detecting instabilities in their signals has arisen. For example, with two hydrogen masers with a 1 in 10^{15} frequency difference, the drift rate of phase due to the frequency difference will be 1fs per second or 3.6ps per hour. No ordinary universal counter [3] would be capable of resolving the difference between the two signals. It is therefore vital that, if a metrologist involved with time and frequency measurement, is to be able to characterise and resolve such standards, then the measurement system drift must be understood and quantified.

Quartzlock have developed an innovative instrument based around the KVARZ frequency difference multiplier that is capable of resolving 1.5 parts in 10^{15} in 100s gate time. The A7 frequency and phase comparator is a 2U rack or bench mount unit with inputs and controls on the front panel. The A7 is interfaced to a computer via a GT200 time interval counter card [4] capable of 100ps resolution without averaging. To complement the device, software has been written to enable the user to perform powerful statistical analysis on the data obtained. In addition, commercially available industry standard software (Stable 32TM) is supplied as standard with the unit[5]

The following paper will provide some background into relevant definitions needed to understand the device, describe the layout of the A7, detail in depth the frequency difference multiplier-, explain the different statistical techniques possible with the accompanying software and thereby analyse the performance of the A7 itself. It is hoped that the reader will gain an understanding of the advances made with this device. To finish, possible applications for the A7 are touched upon as are methods for improving the frequency and phase resolution. [6] [7]

2. Definitions

2.1 Frequency: The input signal frequency is measured by the GT200 universal counter using the most accurate technique available, reciprocal counting coupled to time interpolation. Frequency is measured over some span of time.

2.2 Gate Time: The time between measurements. The gate time defines the averaging time of the measurement. A long gate time will provide average frequency improve accuracy and increase the number of significant figures, but will hide any short-term variation, whereas short gate-times enable characterisation of the short-term frequency variations. The gate time for the GT200 may be set to any desired value between 1 ms and 3200s. In phase/time difference mode the minimum gate time is 1s, setting the minimum τ in Allan Variance calculations to 1s. [4]

2.3 Frequency accuracy: How well the interval between the 1pps output of a clock conforms to the SI second as defined by the Cesium atom. [8] It is also commonly known as the fractional frequency offset.

2.4 Frequency Stability: How stable the frequency is as a function of averaging or integration time, τ , . It is a measure of how the frequency changes as averaged over one interval τ to the next interval τ . International recommendations have made the root Allan variance the accepted measure. [9]

2.5 Reciprocal counting: a method of counting which always makes a period measurement on the input signal. By taking the reciprocal of the period measurement, the frequency of the input signal may be displayed. The two major advantages of the reciprocal counting method are i) The +/- 1 count

Presented at the 31st PTTI meeting in Dana Point, Ca, USA in December 1999

quantization error is independent of the input signal frequency. The resolution of the reciprocal counter is independent of the input signal frequency, if we had a noiseless signal and assuming negligible trigger and time base error ii) The period counting characteristic of the reciprocal technique provides the capability for control of the main gate in real time.

2.6 Time Interval: The elapsed time between an event on the 'start' input and an event on the 'stop' input. All timing functions (on the counter) are measured by the time interpolation technique.

3. Description of the A7

3.1 General Block Diagram

Fig 1 shows the overall block diagram

A full appreciation of the A7 necessitates an understanding of what happens inside. A brief introduction to the device will be given, with further descriptions of the frequency difference multiplier, rubidium oscillator, distribution amplifier and GT200 time interval counter card.

The frequency difference multiplier from IEM KVARZ is the heart of the device. It takes two input signals at either 5 or 10 MHz, multiplies their fractional frequency difference by 1000 (frequency mode) and 10000 (phase/time difference mode), outputting a 5 MHz sine wave with this fractional frequency difference multiplied by 1000 superimposed and a 1 Hz pulse with the fractional frequency difference multiplied by 10000 superimposed.

The rest of the A7 provides a 10 MHz reference signal to the counter, a 1 Hz reference pulse and automatic level switching and monitoring-enabling 5 or 10 MHz input signals to be interchangeably applied.

The reference chain starts with a 10 dB directional coupler that samples the reference signal applied to the freq. difference multiplier. The counter reference is provided by a doubler if the input is 5 MHz, and a direct amplifier / limiter if the input is 10 MHz. The presence of a 5 MHz output from the low pass filter is detected and used to automatically switch between the doubler and the direct path.

The 1 Hz reference pulse is obtained by dividing the input by 5E5 or 10E6 for 5 and 10 MHz input signal respectively. Again the switch over is automatic. The divider used has a reclocked output latch that removes the effect of the divider propagation delay from the reference path. This reduces the effect of temperature changes on the delay. The divider constant may be changed higher or lower by the phase-adjust push buttons. This enables the phase of the 1 Hz reference to be slewed.

Level monitoring is provided on both inputs by AC detectors and window comparators.

3.2 Frequency difference multiplier

Fig 2 gives a simplified block diagram of the frequency difference multiplier

The two measurement inputs are called A and B. An input from the reference source at 5 or 10 MHz is connected to A, and an input from the device under test (DUT) is connected to B. The inputs A and B are interchangeable. Typically the 10 MHz reference source is likely to be at least a rubidium oscillator, preferably an active or passive hydrogen maser, or a Cesium beam. This provides the user with the opportunity to take advantage of the units measurement capability.

Presented at the 31st PTTI meeting in Dana Point, Ca, USA in December 1999

Both inputs (let us assume they are at 10 MHz) are multiplied using harmonic multipliers to 100 MHz and then mixed down to a 1 MHz Intermediate Frequency (IF) using an internal Local Oscillator (LO) at 99 MHz. As the LO is common to both channels, any phase jitter or drift will eventually be removed when the channels are compared. The LO is phase locked to one of the inputs by comparing the output of a divide by 99 circuit with the 1 MHz IF.

The 1 MHz signals are then multiplied to 10 MHz. The 10 MHz from channel B is then converted to 9 MHz by mixing with a 1 MHz signal derived from the LO. The 10 MHz from channel A is mixed with the 9 MHz from channel B to give the 1 MHz difference.

The basic 1 MHz difference signal is made available at the front panel (of the frequency difference multiplier, not the A7), and is then processed further as follows:

A crystal filter removes side bands created by all the mixing processes, but results in a reduced noise bandwidth. The 1 MHz signal is then multiplied by 5 to give 5 MHz. This 5 MHz is available at the frequency difference multiplier front panel.

The filtered 1 MHz difference signal is then mixed down to 100 kHz by means of a 900 kHz LO obtained by division from the 99 MHz LO. This 100 kHz signal is then divided by 100000 to give 1 Hz pulses, which are output to the frequency difference multiplier front panel.

3.3 Distribution Amplifier

The A7 is fitted with a linear 4-way distribution amplifier designed for standard frequency distribution between 1 MHz and 100 MHz. It is ideal for distribution of the 5 or 10 MHz reference signal applied to the front panel input. A Hydrogen maser signal may be distributed 4 ways, providing 1 output for the A7 reference input and 3 spare maser quality outputs.

The circuit is based on a number of balanced linear amplifiers with high reverse isolation and low phase noise. These are the output amplifiers. The input amplifier drives the passive power splitter and is a modified version of the output amplifier with gain control. Typical isolation at adjacent outputs of >110 dB @10 MHz, from output to input of >110 dB @10 MHz and crosstalk (input to input) of >80 dB @10 MHz. Phase noise is -165 dBc @ 100 Hz offset. This ensures that the hydrogen maser signal (or signal of similar quality) retains its original input characteristics. Apart from sharing the same power supply, the distribution amplifier is completely separate from the A7 circuits. The gain of the distribution amplifier is adjustable by the user (6dBm to 13 dBm required for the reference input) [10]

3.4 Rubidium Frequency Standard

A high stability, low sensitivity, Rubidium reference oscillator may be integrated into the measurement system, enabling generation of Rb quality reference signals. Typical frequency stability is $5E-12/\tau^{1/2}$, frequency accuracy of $5E-11$ and aging of $<4E-11$ per month.

This makes the A7 a complete instrument, capable of providing, distributing and analysing frequency standards. Whilst the Rb will cover most requirements, to fully exploit the resolution of the A7 an Active Hydrogen Maser should be used in a temperature controlled room. The unit will then achieve the quoted $1.5E-15$ resolution in 100s and will enable short term stability characterisation of even the highest quality quartz oscillators and passive hydrogen masers. The difference between two active

Presented at the 31st PTTI meeting in Dana Point, Ca, USA in December 1999

hydrogen masers should be detectable. Forthcoming tests at the PTB in Germany should confirm this idea.

3.5 GT200 Time Interval Counter Card

The signals carrying the frequency difference information are output to, and measured by, the GT200 universal counter using the most accurate technique available, reciprocal counting coupled to time interpolation. [2] The GT200 is a PC based counter card, which fits into one of the spare ISA slots. It has a configurable address (settable in either HEX or decimal) to avoid conflict with other ISA cards (like SoundBlaster or internal Modems). The GT200 has associated DOS based software, which provides the counter virtual front panel. This enables the user to operate the counter like a normal universal counter, with the normal range of functions totalise, and trigger, arming, pacing, calibration etc.). Communication errors between the driver and windows force the user to operate the program under DOS. Data is saved in ASCII format, with the appropriate DOS path and .DAT file extension.

4. Modes of Operation

There are two ways to acquire data using the A7, depending upon which mode the frequency difference multiplier is operated in.

4.1 Frequency mode

Fig 3 Test set-up in frequency mode

This is most useful for adjustment purposes (i.e. calibration), as a short gate may be used with sufficient resolution to adjust even high quality atomic frequency standards, like Rubidium. It is also ideal for very short gate times ($\tau < 1s$) where the phase time difference mode cannot be used (time between measurements limited to $\geq 1s$).

The various outputs from the frequency difference multiplier carry the frequency difference information between the reference and the DUT as an offset from the nominal frequency. The fractional frequency difference between the inputs is multiplied by 1000 for the 1 and 5 MHz outputs and by 10000 for the 1 Hz outputs

If we assume that the inputs to channel A, channel B and LO are $F_1 + \Delta F_1$, $F_2 + \Delta F_2$ and $F_3 + \Delta F_3$ respectively then the outputs from the frequency difference multiplier are (see Fig 2)

- i) 1 MHz: $100(F_1 - F_2) + 100(\Delta F_1 - \Delta F_2) + (F_3/99) + (\Delta F_3/99)$
- ii) 5 MHz: $500(F_1 - F_2) + 500(\Delta F_1 - \Delta F_2) + (5F_3/99) + (5\Delta F_3/99)$
- iii) 1 Hz: $100(F_1 - F_2) + 100(\Delta F_1 - \Delta F_2) + (11/10890)F_3 + (11/10890)\Delta F_3$

If we then make the necessary assumption that the signals to the reference and measurement signals are *nominally* identical (i.e. $F_1 = F_2$), then the first terms in the 3 above expressions disappear. If we then assume, as we must to avoid unambiguous results, that the error in the signal applied to the reference input is negligible when compared to that from the DUT (i.e. any frequency instability arises solely from the DUT & assuming a provisional TUR of 10:1), then the second terms in the 3 above expressions become functions of ΔF_1 (the error in the signal from the DUT). Then we neglect

Presented at the 31st PTTI meeting in Dana Point, Ca, USA in December 1999
the final terms in each expression, as they contribute negligibly to the final answer). We therefore end up with the following expressions

- i) 1 MHz: $100\Delta F_1 + (F_3/99)$
- ii) 5 MHz: $500\Delta F_1 + (5F_3/99)$
- iii) 1 Hz: $100\Delta F_1 + (11/10890) F_3$

Let us consider a situation where the LO is at 99 MHz, the measurement and reference inputs are nominally at 10 MHz and the measurement input signal has a frequency offset of 1 Hz (ΔF_1), there exists a fractional frequency difference (defined as $(F_{\text{meas}} - F_{\text{ref}})/F_{\text{ref}}$) of 1 in 10^7 .

If we consider the output from the 5 MHz output we get:

$$\begin{aligned} \text{Output from 5 MHz part} &= 500(\Delta F_1) + (5F_3/99) \\ &= 500*1 + (5*99*10^6)/99 \text{ Hz} \\ &= 5 \text{ MHz} + 500 \text{ Hz} \\ &= 5.000500 \text{ MHz} \end{aligned}$$

The error in the 5 MHz output is therefore 1 part in 10^4 , whereby a fractional frequency difference multiplication of 10^3 has taken place

Whilst the above example illustrates the multiplication clearly, the actual allowable frequency difference measurement range is much less due to the presence of a narrow bandwidth filter (to filter out the side bands created by the mixers and harmonic multipliers). Indeed the maximum fractional frequency difference between the inputs is 1 part in 10^8 .

Similar analysis on the signal processed to the 1 Hz output shows a fractional frequency difference multiplication of 10^4 has taken place. If a similar situation as above is considered the output frequency will be 1.001 Hz (a fractional difference from the nominal 1 Hz of 10^3).

Included in the software written for the A7-GT200 data acquisition systems are 5 set-up files for viewing signal characteristics of the DUT upon input from the A7 to the GT200. There are 3 set-up for viewing whilst in frequency mode. These pre-set the counter parameters like trigger level, offset and multiplication factors. They may be accessed via the counter virtual front panel.

- i) **FREQ1**: Sets the counter to directly display the 5 MHz frequency output of the A7, with the frequency difference information (*500 for the 10 MHz inputs) superimposed, without normalisation.
- ii) **FREQ2**: Shows the frequency difference in Hz corrected to the input of the A7 (i.e. the frequency offset between the inputs). This is the raw un-normalised frequency offset of the DUT. The normalisation and offset factor must be altered in this set up file for 5 MHz input signals. (default set to 10 MHz)
- iii) **FREQ3**: Shows the fractional frequency difference between the inputs of the A7. This is also commonly known as accuracy. This is most useful for real time calibration of the DUT.

4.2 Phase/time difference mode

When stability of signals with averaging time, τ , from 1 second to 10000 seconds (or longer) is required, operation of the frequency difference multiplier in phase/time difference mode is

Presented at the 31st PTTI meeting in Dana Point, Ca, USA in December 1999

recommended. Software is supplied allowing simple but powerful analysis (using all the common statistical measures for characterisation of frequency and time signals) of the DUT from a block of phase data. (more information in section 5) [11] One benefit of this method is that the frequency difference information can always be obtained by differentiating time difference over a required τ (averaging time).

A divider on the auxiliary board provides a suitable frequency reference at 1 Hz from the reference input. This is at an identical nominal frequency to the 1 Hz output of the frequency difference multiplier. This second frequency is the one carrying the frequency difference information. The GT200 card then measures the time interval between a rising edge of the frequency difference signals and that of the reference. The rate of change of time interval divided by the previously mentioned fractional frequency difference multiplication factor for the 1 Hz output (10000) will give the fractional frequency difference between the inputs. If the rate of change of time interval measured by the GT200 is 1ms/s (1 part in 10^6), when divided by 10000, gives a fractional frequency difference between the DUT and the reference of 1 part in 10^{10} . The maximum allowable frequency difference between the sources, if the results from the comparator are to be 100% reliable, is 1 part in 10^9 . [12] For a 10 MHz signal, this is an offset in the DUT of 0.01 Hz. Whilst this may seem restrictive, it is important to remember that if devices are being tested with greater offsets than this, a normal universal counter, with ns resolution [3] would be sufficient. The A7 is designed for high-end measurement, where the likely offsets will very often be much smaller than this (a hydrogen maser has a typical offset of parts in 10^{13}). Long term measurements of the offsets from GPS disciplined OCXO and Rubidium will often be parts in E-14.

As for the frequency mode, the phase/time difference mode also has set-up files, for displaying important signal information

i) **PHASE1**: Shows the time difference in seconds between adjacent edges of a 1 Hz square wave derived from reference input to the A7 and a 1 Hz pulse derived by processing the signal from the measurement input to the A7 through the frequency difference multiplier. The fractional frequency difference between the inputs will have been multiplied by 10000. It is important to understand that only changes in time difference (corresponding to frequency difference) are of interest. A change of reading on the counter of 1 ms every second corresponds to a rate of change of phase at the A7 inputs of 100ps ($1.10^{-6}/10000 = 10^{-10}$). A change of 100ps every second is equivalent to a frequency difference at the inputs of 10^{-10}

ii) **PHASE2**; Shows the time difference in seconds at the input of the A7. A phase change of 100 μ s at the input of the A7 will equate to a full 1 second phase change at the output

5. Software

Development of the A7 frequency and phase comparator, necessitated accompanying software so that data gained from the A7 during a phase/time interval run could be analysed.

The decision was made to write several routines in MathCad. One of the advantages of this method was that the user had full control over the routines he was using. Therefore should he require additional features they were easy to add into the existing worksheet. In addition due to the capability of MathCad, unlimited data entry is possible. This allowed long data runs, which enable characterisation of signals out to longer averaging times.

Presented at the 31st PTTI meeting in Dana Point, Ca, USA in December 1999

The best method of characterising a frequency standard against a master standard like a rubidium oscillator or a hydrogen maser is the statistical analysis of phase/time difference data file. It is important to understand that frequency is the rate of change of phase, and that fractional frequency difference has an exact correspondence with the slope of a time difference plot. For example, if during a run of 100 seconds the mean slope of the time difference data was 100ps in 100 seconds, then the fractional frequency difference would be 10^{-10} averaged over 100 seconds.

The routines written for the A7 include both first and second difference variances

5.1 First difference variances take into account frequency offsets between the sources. There are two such first difference variances

i) **Fractional Frequency Offset** at an averaging time τ will give the same result as the average of a large number of frequency counter readings with a gate time of τ .

ii) **Mean Fractional Frequency Offset** is similar but will calculate a mean slope over τ using intermediate data point.

5.2 Second difference variances are concerned with frequency stability and will ignore a fixed frequency offset. There are many of these but we have confined ourselves to the 3 most commonly used.

i) **Allan Variance**, abbreviated $\sigma_y^2(\tau)$ or AVAR is the most commonly used measure of frequency stability.

$$s_y^2(t) = 1/2 t^2 \langle (D^2 x)^2 \rangle \quad (1)$$

This was originally developed because atomic frequency standards do not generate a constant frequency output contaminated solely by white noise and the output of such a frequency standard cannot be averaged to get rid of the noise. [13][14] Therefore the usual statistical measures like standard deviation and mean cannot be used to characterise frequency standards. AVAR is excellent at characterising the intermediate to long-term frequency stability of clocks and oscillators.

ii) **Modified Allen Variance**, abbreviated $\text{MOD}\sigma_y^2(\tau)$ or MVAR, is similar to Allen Variance, except that it calculates mean slopes using intermediate data points in a similar way to mean fractional frequency offset.

$$s_y^2(t) = 1/2 t^2 \langle (D^2 \bar{x})^2 \rangle \quad (2)$$

One of the advantages conferred thereby is that MVAR can distinguish between white noise PM and flicker noise PM, whereas AVAR cannot. [13][14] This is the type of noise present in active hydrogen masers and quartz oscillators at short averaging times

Both of the above are very suited to the characterisation of frequency instabilities of frequency standards.

iii) **Time Variance**, abbreviated $\sigma_x^2(\tau)$ or TVAR is for use when time is the parameter of interest, rather than frequency

$$s_x^2(t) = 1/6 \langle (D^2 \bar{x})^2 \rangle \quad (3)$$

Presented at the 31st PTTI meeting in Dana Point, Ca, USA in December 1999

In many ways TVAR is similar to MVAR, and has many of the improvements over AVAR. TVAR is directly related the MVAR and is used for the characterisation of clocks. TVAR is the recommended method of characterisation of frequency standards intended for use within the telecommunications industry. In the MathCad software it is possible to view all three second-difference variances on the same graph for comparison.

At the present time the company has developed 2 routines, **TVAR6** which calculates second difference variances, and **MVAR** which calculates first difference variances. Each routine has been extensively debugged and updated. The company also uses the commercially available Stable32 frequency stability analysis package to analyse and characterize frequency stability, offset, drift, outliers and noise types present.

6. Results

Fig 4 shows the A7 connections for noise floor and drift measurement

To verify the performance of the A7, both the A7 noise floor and long-term drift must be established. Driving the measurement and reference inputs from the two outputs of an inductive power splitter ensures identical inputs and eliminate source α distribution amplifier noise. In addition care must be taken to use type N connectors with short cables. The 10 MHz source must not exceed the maximum absolute specification of 1 in 10^8 in frequency mode and 1 in 10^9 in phase/time difference mode. Failure to provide a good quality source with good short-term stability and low phase noise may degrade the apparent noise floor of the A7 in the short term.

Noise floor measurements are possible in both frequency and phase/time difference modes. It is far easier to measure the noise floor in phase/time difference mode, since in frequency mode a separate run must be made for each value of τ required. However, simplified noise floor measurements in frequency mode reveal a standard deviation of +/- 2E-12 and 2E-13 for 100ms and 1s gate times respectively. [12]

In contrast, in phase/time difference mode a block of data is accumulated and then analysed in MathCadTM. In this mode, the shortest time between readings is set to 1s, whilst the longest is determined by using the pacing function on the GT200 virtual front panel and may be as long as 3200 seconds. One advantage of this is the ability to perform extremely long runs without making the data files too large. Because Allan variance is a statistical measure, the maximum sensible τ is the total-run-length/10. Therefore a run time of 10000 seconds without pacing allows Allen variances from 1s to 1000s to be calculated. If the pacing is set to 10s, a run of 10000 seconds will generate only 1000 data points (and hence a data file a tenth the size). It will also raise the minimum τ to 10s because Allan Variance cannot be calculated for τ less than the time interval between readings. To fully explore the noise floor of the A7 two zero drift runs were made in phase/time difference mode, one with a sampling rate of 1 Hz (time between readings 1s) and length 10000 seconds. This allows Allan Variances to be calculated for τ between 1s and 1000s. The second run should have a sampling rate of 0.1 Hz (prescaling have set the time between readings to 10s) and length 100000s. This will enable Allan variances to be calculated for τ between 10s and 10000s. To allow the unit to stabilise, it was allowed 12 hours to warm up before the measurement runs were started. The specifications state a short term stability of 1.5E-13/gate time, resulting in 1.5E-13, 3E-14 and 3E-15 for 1s, 10s and 100s gate times (τ). Initial results suggest even better performance than this with Allen variances of 5E-14, 8E-15, 1.5E-15 and 3.5E-16 for 1s, 10s, 100s and 1000s gate times (τ). [12]

Fig 5 Allan Variance Noise Floor

Presented at the 31st PTTI meeting in Dana Point, Ca, USA in December 1999

Assuming a constant ambient temperature, the A7 has been observed to drift only 2ps/hr, with the contribution of a 1°C temperature change being less than an additional 10ps. A single shot rms. Resolution of 0.3ps was also measured, a remarkable result enabling the A7 to easily resolve the 3.6ps/hr drift rate between two hydrogen masers. It is important to remember that active hydrogen masers only achieve their stated stability and offset in a highly temperature stabilised environment.

7. Benefits and Applications

The primary benefits of the A7 frequency and phase comparator are improved resolution and reduced measurement time. Fast measurements with high accuracy permit greater knowledge of the stability of the signal.

The applications for an instrument capable of such resolution are anticipated to be numerous, ranging from national standards and calibration laboratories, through Cesium, Rubidium and Quartz production to time transfer measurements. Future work is underway to reduce the size of the A7, increasing the range of frequency's permitted for measurement and allowing for greater than 1 Hz sampling rate in phase mode. This will allow Allan Variances of <1s to be calculated. [7]

8. References

- [1] Fundamentals of Electronic Counters. HP Application Note 200 Electronic Counter Series
- [2] HP 53100 Series HP Counters Technical Data.
- [3] HP 53131A/132A 225 MHz HP Universal Counter Operating Guide (Manual Part Number 53131-90021)
- [4] Guide Technology Inc. GT200 Time Interval Counter Card manual.
- [5] Manual for Stable32, Version 1.21 by Hamilton Technical Services March, 1999
- [6] Quartzlock Manual for Model A7 Frequency and Phase Comparator, April 1999, R.Percival and Dr CJM Little
- [7] Private communication with Dr Cosmo Little and Clive Green, Feb-Nov. 1999
- [8] Standard terminology for fundamental frequency and time metrology- David W. Allan et al, Proc.42nd Annual Frequency Control Symposium, 1988, pp 419-425
- [9] An Introduction to frequency calibration- Michael Lombardi, Time and Frequency Division, NIST
- [10] Quartzlock A5 Distribution Amplifier Data Sheet
- [11] Time Domain Characterization of Modern Time and Frequency Standards, Richard Percival, Quartzlock (UK) Ltd, To be presented at MSC2000, Anaheim, California, Jan 2000
- [12] Quartzlock Data Sheet for A7 Frequency and Phase Comparator, April 1999, R.Percival, Dr CJM Little and CR Green
- [13] Time and Frequency Metrology: Current Status and Future Considerations, David W. Allan, Time and Frequency Division, NIST, Boulder, Colorado, Proc. 5th European Frequency and Time Forum (EFTF), March 1991, pp 1-9
- [14] Introduction to the Time Domain Characterisation of Frequency Standards- James Jespersen, Time and Frequency Division, NIST, Boulder, Colorado.

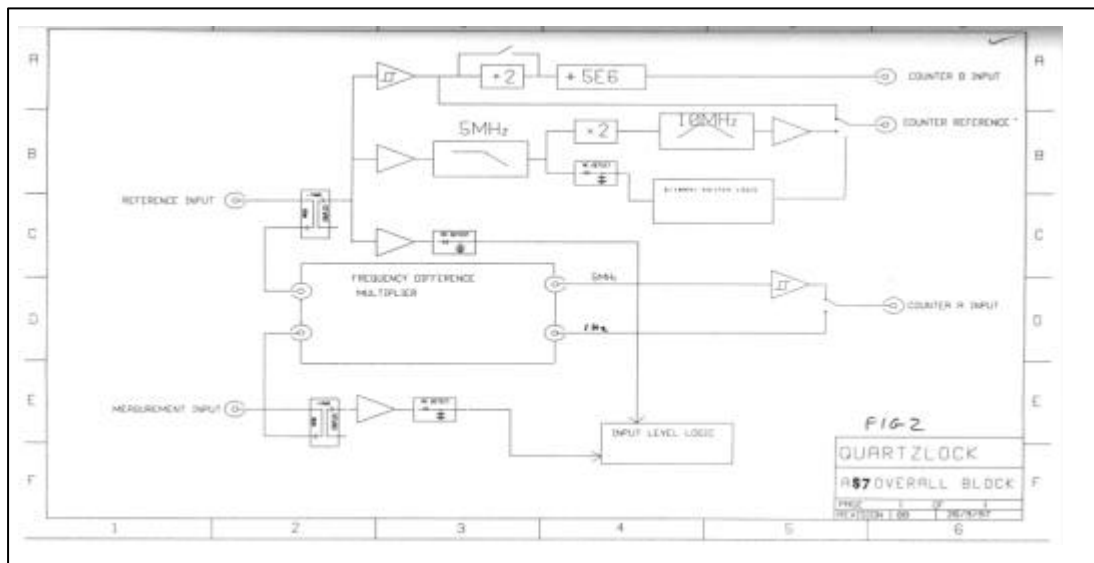

Fig 1 Overall block diagram

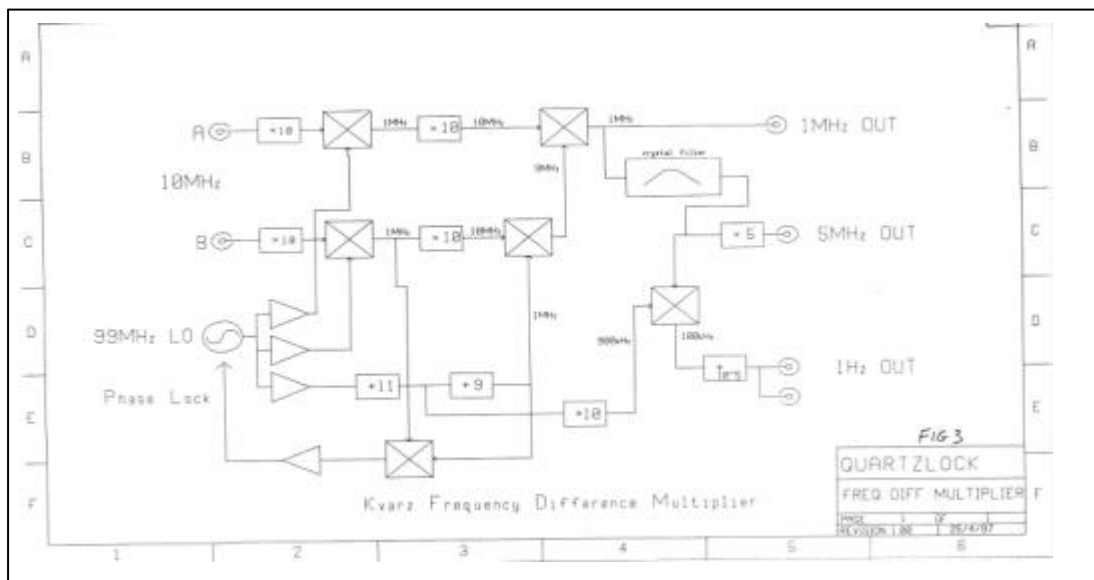

Fig 2 Simplified block diagram of the frequency difference multiplier

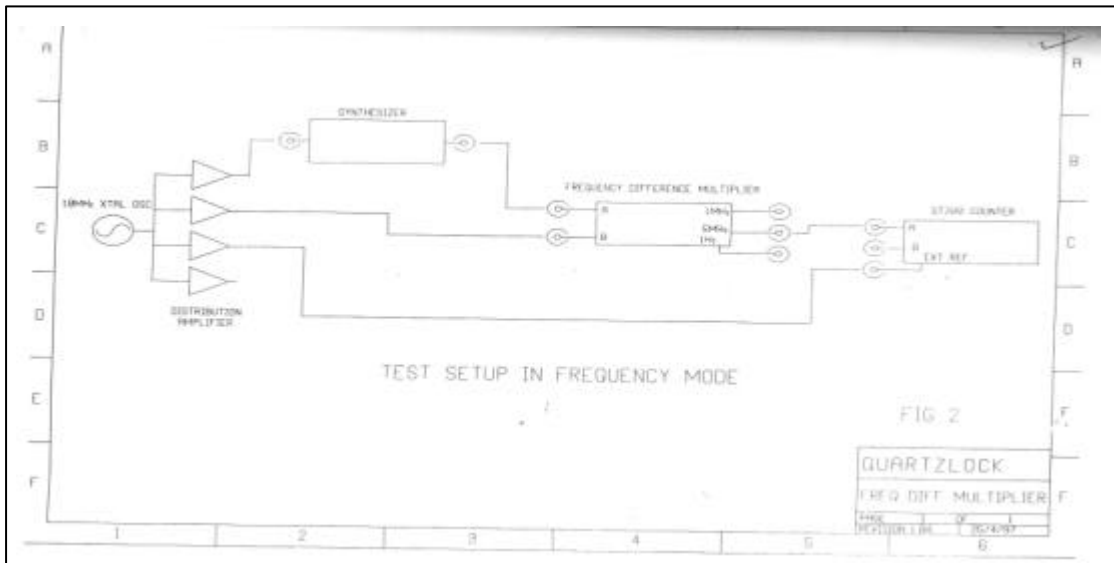

Fig 3 Test set-up in frequency mode

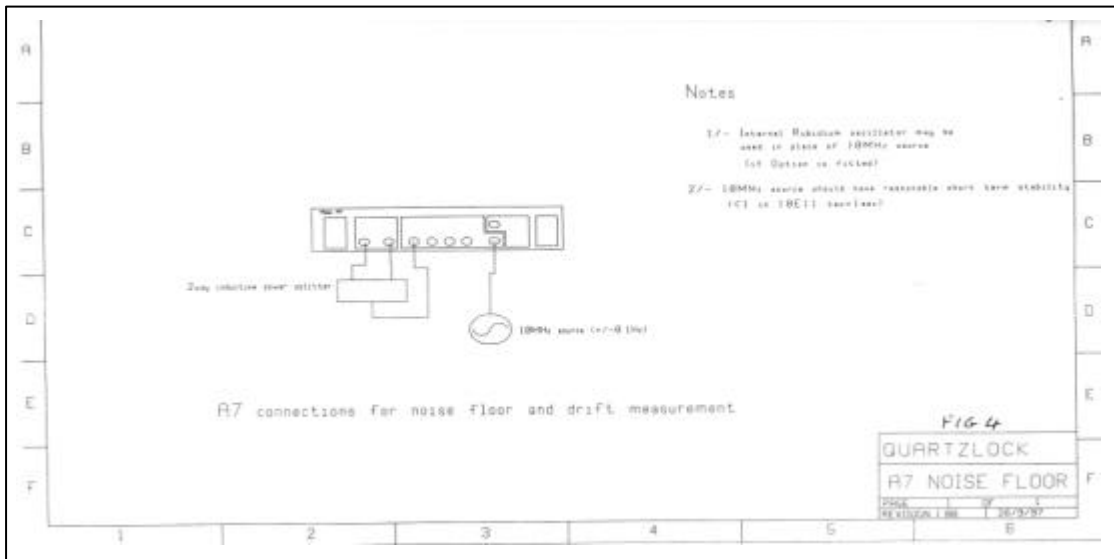

Fig 4 A7 connections for noise floor and drift measurement

Presented at the 31st PTTI meeting in Dana Point, Ca, USA in December 1999

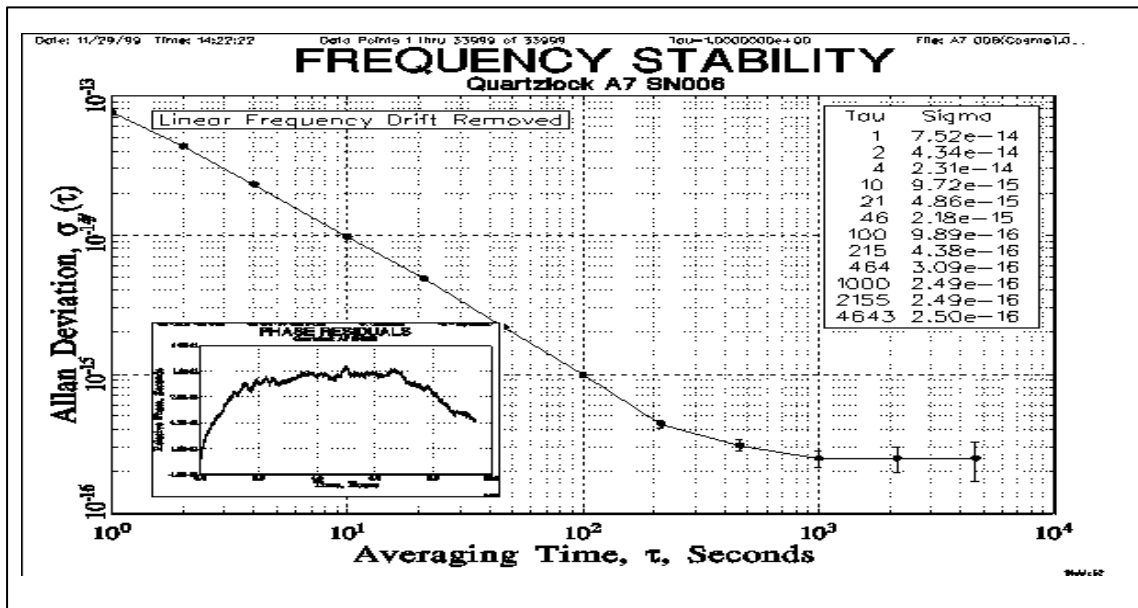

Fig 5 Allan Variance Noise Floor